

INSTRUMENT CATHODE-RAY TUBE

- 14 cm diagonal rectangular flat face
- direct - view storage tube
- internal graticule
- for oscilloscope applications

QUICK REFERENCE DATA

Final accelerator voltage	$V_{g10(l)}$	8,5 kV
Minimum useful scan area		90 mm x 72 mm
Deflection coefficient		
horizontal	M_x	9,5 V/div
vertical	M_y	4,1 V/div
Writing speed		2,5 div/ μ s

OPTICAL DATA

Screen		metal-backed phosphor
type		GH, colour green
persistence, non-store mode		medium-short
persistence, store mode		variable
Useful screen area		min. 90 mm x 72 mm
Useful scan area		min. 90 mm x 72 mm
Spot eccentricity in horizontal and vertical directions		max. 6 mm
Internal graticule		typ. 95; see Fig. 6

HEATING

Writing section

Indirect by AC or DC*		
Heater voltage	V_f	6,3 V
Heater current	I_f	240 mA
Heating time to attain 10% of the cathode current at equilibrium conditions		approx. 5 s

Viewing section

Indirect by DC*		
Heater voltage	V_{FGf}	12,6 V
Heater current	I_{FGf}	240 mA
Heating time to attain 10% of the cathode current at equilibrium conditions		approx. 5 s

* Not to be connected in series with other tubes.

MECHANICAL DATA**Dimensions and connections** (see also outline drawings)

Overall length (socket included)	≤ 452 mm
Faceplate dimensions (final accelerator contact excluded)	118 ± 0,5 mm x 98 ± 0,5 mm

Net mass approx. 1,3 kg

Mase 14 pin, all glass

Mounting position

The tube can be mounted in any position. It should not be supported by the base alone or near the base region, and under no circumstances should the socket be allowed to support the tube. The tags near the screen should not be subjected to mechanical stress. Avoid any force on the side contacts.

Accessories

Socket (supplied with tube)	type 55566
Side contact connector (7 required)	type 55561
Small ball contact connector (5 required)	type 4022 102 21590

FOCUSING

electrostatic

DEFLECTION

double electrostatic

x-plates

symmetrical

y-plates

symmetrical

Angle between x and y-traces

90 ± 1°

Angle between x-trace and x-axis
of the internal graticule

≤ 5°*

CAPACITANCES

x ₁ to all other elements except x ₂	C _{x1(x2)}	5,5 pF
x ₂ to all other elements except x ₁	C _{x2(x1)}	5,5 pF
y ₁ to all other elements except y ₂	C _{y1(y2)}	3,5 pF
y ₂ to all other elements except y ₁	C _{y2(y1)}	3,5 pF
x ₁ to x ₂	C _{x1x2}	2,5 pF
y ₁ to y ₂	C _{y1y2}	2 pF
g ₁ to all other elements	C _{g1}	6 pF
k to all other elements	C _k	3,5 pF
g ₃ to all other elements	C _{g3}	4,5 pF
g ₇₋₁ to all other elements	C _{g7-1}	30 pF
g ₇₋₂ to all other elements	C _{g7-2}	65 pF
g ₇₋₃ to all other elements	C _{g7-3}	60 pF
g ₉ to all other elements	C _{g9}	60 pF
g ₁₀ to all other elements	C _{g10}	80 pF
FGA to all other elements	C _{FGA}	15 pF
FGK' to all other elements	C _{FGK'}	8 pF
FGK'' to all other elements	C _{FGK''}	8 pF

Dimensions in mm

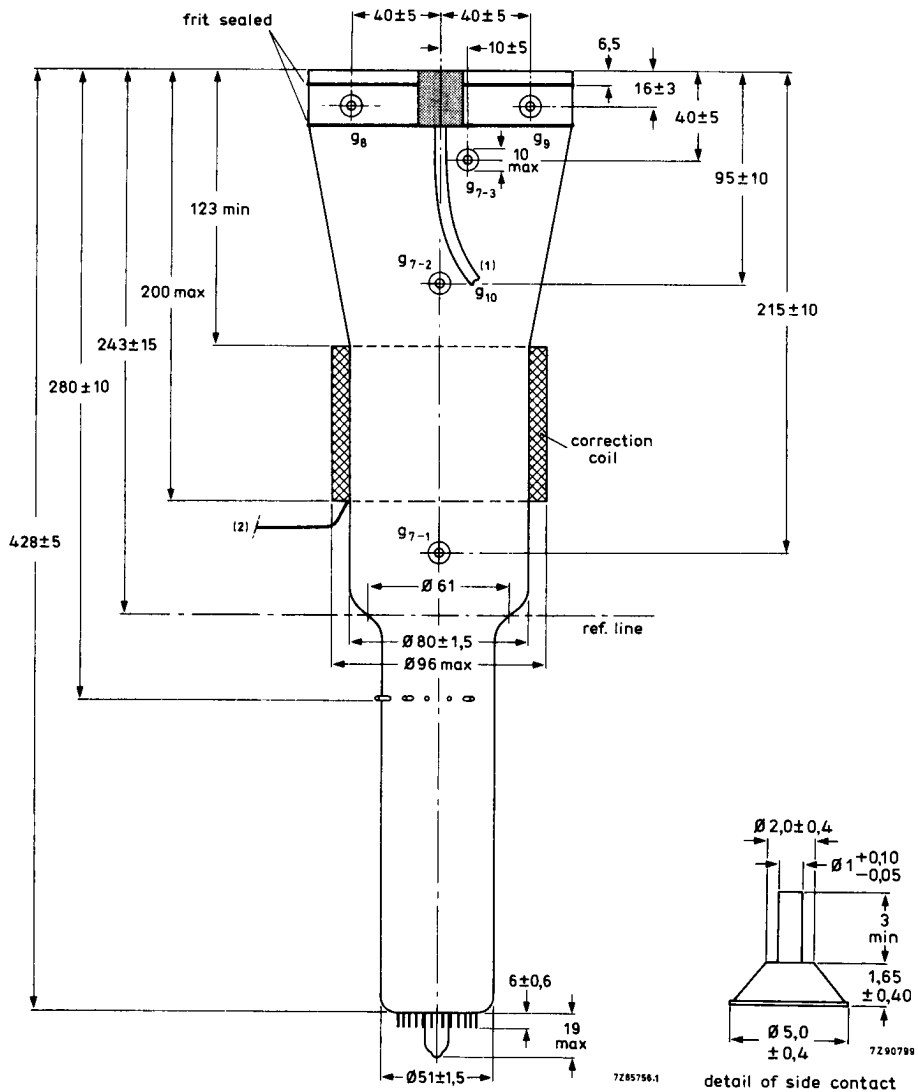

Fig. 1 Outlines.

- (1) Minimum cable length is 420 mm.
 (2) Minimum length of connecting leads is 350 mm.

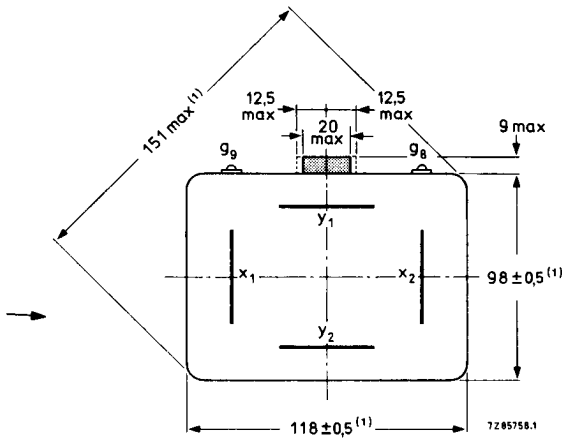

Fig. 2 Top view.

(1) The bulge at the frit seal may increase the indicated maximum dimensions by not more than 3 mm.

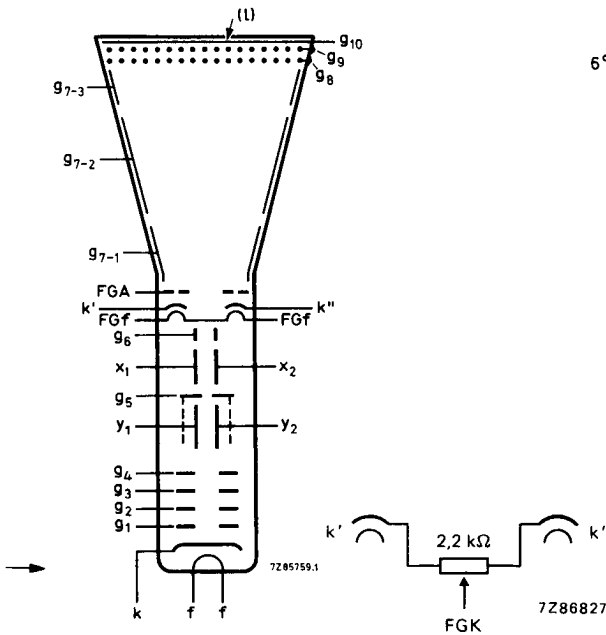

Fig. 4 Electrode configuration.

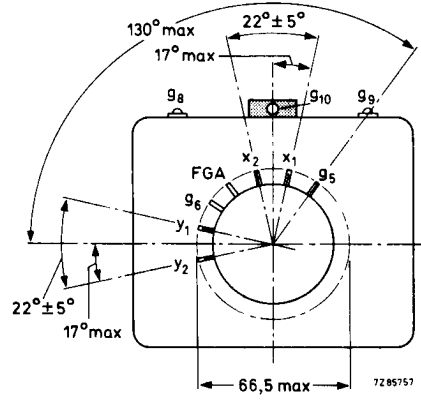

Fig. 3 Bottom view and side-contact arrangement.

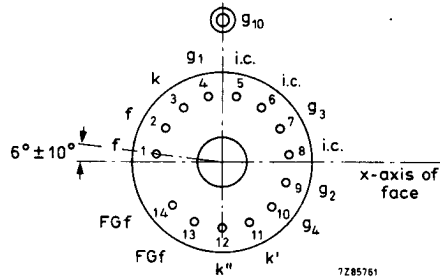

Fig. 5 Pin arrangement; bottom view.

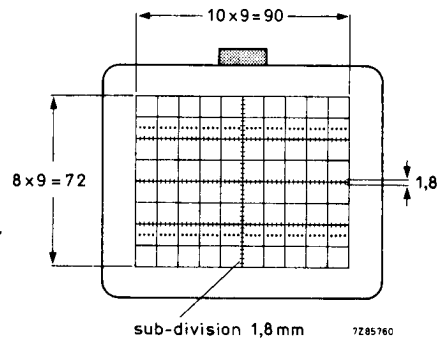

Fig. 6 Internal graticule
 colour of graticule: black;
 line width: 0,2 mm;
 dot diameter: 0,4 mm.

INTERNAL GRATICULE ALIGNMENT

The internal graticule is aligned with the faceplate by using the faceplate reference points A1, A2 and A3, see Fig. 7.

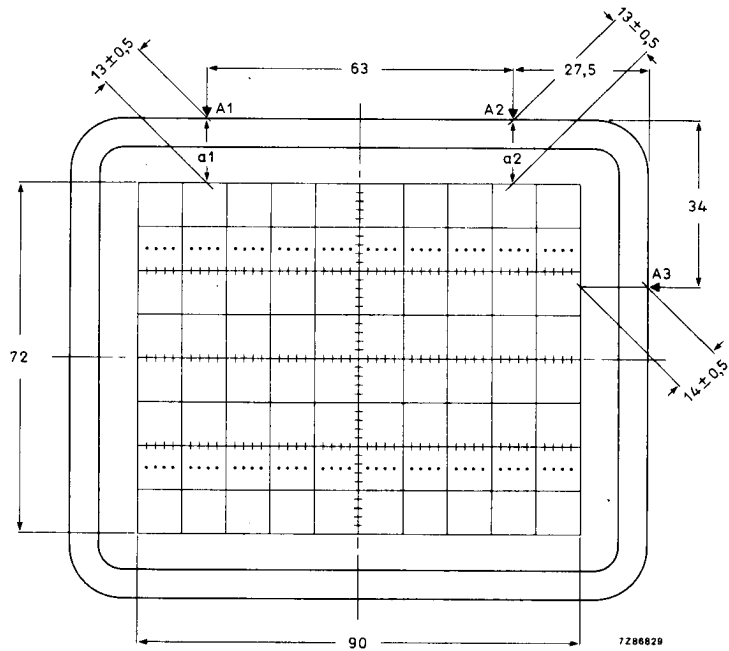

Fig. 7 Front view of tube with internal graticule.
 $|a1 - a2| \leq 0,3$ mm.

TYPICAL OPERATION

Conditions

Writing section *

Final accelerator voltage	$V_{g10(\ell)}$	8500 V	see note 1
Geometry control electrode voltage	V_{g6}	1500 ± 100 V	
Deflection plate shield voltage	V_{g5}	1500 V	see note 2
Astigmatism control electrode voltage	V_{g4}	1500 ± 50 V	see note 3
Focusing electrode voltage	V_{g3}	400 to 600 V	
First accelerator voltage	V_{g2}	1500 V	
Cut-off voltage for visual extinction of focused spot	$-V_{g1}$	45 to 85 V	

* Above voltages are with respect to writing gun cathode k.

Viewing section

Refer to Fig. 8 for typical operating values.

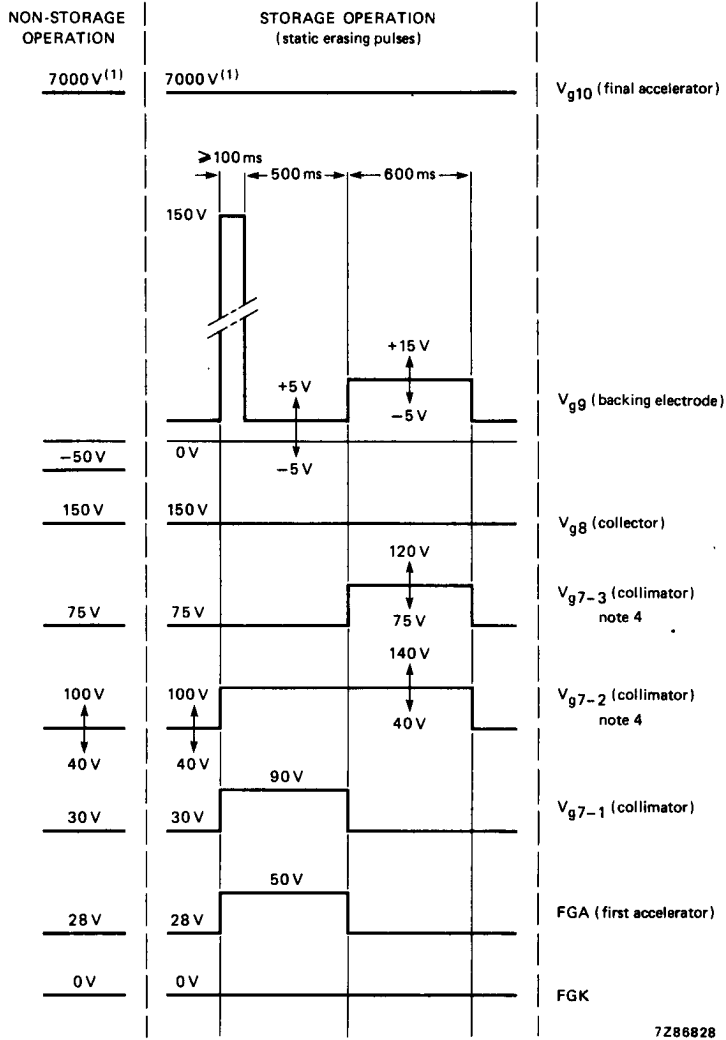

Fig. 8 Diagram of non-storage and storage operation.

(1) With respect to FGA, all other voltages with respect to viewing gun cathode FGK (see Fig. 4 and note 11).

Performance**Useful scan**

horizontal	min.	90 mm	
vertical	min.	72 mm	

Deflection coefficient

horizontal	M_x		9,5 V/div
		max.	10,5 V/div
vertical	M_y		4,1 V/div
		max.	4,4 V/div

Line width at the centre of the screen

l.w.	0,35 mm	see note 5
------	---------	------------

Writing speed in storage operation

just black	\geq	250 div/ms	} see note 6
max. write	\geq	2,5 div/ μ s	

Storage viewing time

just black	\geq	90 s	} see note 7
max. write	\geq	15 s	

Deviation of deflection linearity

max.	2 %	see note 8
------	-----	------------

Geometry distortion

see note 9

Grid drive for 10 μ A beam current

V_d	approx.	25 V
-------	---------	------

Grid drive for specified writing speed

V_d	max.	45 V
-------	------	------

Total cathode current of both viewing guns

at FGA = 28 V	approx.	1 mA
at FGA = 50 V	approx.	2 mA

LIMITING VALUES (Absolute maximum rating system)**Writing section** (voltages with respect to writing gun cathode k)

Final accelerator voltage	$V_{g10(\ell)}$	max. 9000 V min. 7000 V
Geometry control electrode voltage	V_{g6}	max. 2100 V
Deflection plate shield voltage	V_{g5}	max. 2000 V
Astigmatism control electrode voltage	V_{g4}	max. 2100 V min. 1200 V
Focusing electrode voltage	V_{g3}	max. 1000 V
First accelerator voltage	V_{g2}	max. 2000 V min. 1250 V
Control grid voltage		
positive	V_{g1}	max. 0 V
negative	$-V_{g1}$	max. 200 V
Cathode to heater voltage		
positive	V_{kf}	max. 125 V
negative	$-V_{kf}$	max. 125 V
Voltage between astigmatism control electrode and any deflection plate	$V_{g4/x}$ $V_{g4/y}$	max. 500 V max. 500 V
Grid drive, averaged over 1 ms	V_d	max. 30 V
Screen dissipation	W_{ℓ}	max. 8 mW/cm ²

Viewing section (voltages with respect to viewing gun cathode FGK)

Final accelerator voltage	$V_{g10(\ell)}$	max. 7500 V min. 5500 V
Backing electrode voltage		
storage operation	V_{g9}	max. +150 V min. -5 V
non-storage operation	$-V_{g9}$	max. 50 V min. 25 V
Collector voltage	V_{g8}	max. 180 V min. 120 V
Collimator voltage	$V_{g7-1}, V_{g7-2}, V_{g7-3}$	max. 200 V min. 0 V
First accelerator voltage	V_{FGA}	max. 60 V min. 0 V
Cathode to heater voltage		
positive	$V_{k'FGf}, V_{k''FGf}$	max. 125 V
negative	$-V_{k'FGf}, -V_{k''FGf}$	max. 125 V

OPERATING NOTES

Modes of operations

Non-storage mode

For non-storage operation the front mesh V_{g9} is set to -50 V with respect to FGK.

The viewing guns should not be switched off in this mode of operation since slight variations in raster geometry and deflection sensitivity might otherwise be caused.

Variable persistence mode

a. Dynamic erasure

Dynamic erasure can be achieved by applying extra erasing pulses of positive polarity to the backing electrode V_{g9} . The amplitude of these extra pulses is equal to that of the original erasing pulse, the frequency is 120 Hz and the persistence of the display can be controlled by varying the duty factor.

b. Static erasure (Fig. 8)

If no dynamic erasing pulses are applied the storage time is limited by the potential shift of the storage layer due to landing of positive ions.

In order to erase a stored display, V_{g9} is increased to 150 V for 100 ms and then returned to its original potential for about 500 ms; after that, an erasing pulse of positive polarity (max. 15 V) and a duration of 600 ms should be applied.

While the erasing pulse amplitude is to be adjusted with zero d.c. level for "just black", the background illumination can be changed — even with a stored signal — by varying the d.c. level for optimum contrast or maximum writing speed.

Background equality can be optimized by balancing the viewing gun cathodes by means of a potentiometer of 2,2 k Ω , proper collimator adjustment, and by increasing V_{FGA} , V_{g7-1} , V_{g7-2} and V_{g7-3} in positive direction during erasure.

Before first installation, depending on transport conditions, demagnetization of the tube face region may be necessary.

NOTES

1. These values are valid at cut-off of both flood guns and the writing gun. The HT unit must be capable of supplying 0,5 mA. To protect the tube against excessive surge current during erasure, an RC network as shown in Fig. 9 must be connected in series with the screen terminal lead; the resistance of 15 to 20 M Ω includes the internal resistance of the HT supply.

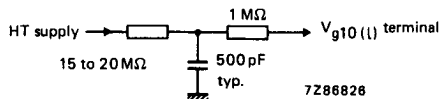

Fig. 9 RC network.

2. This voltage should be equal to the mean y-plate potential. The mean x and y-plate potentials should be equal for optimum spot quality.
3. When putting the tube into operation, the astigmatism control voltage should be adjusted only once for optimum spot size in the screen centre. The control voltage will be within the stated range, provided the conditions of note 2 are adhered to.
4. The collimator electrode voltage V_{g7-2} and V_{g7-3} should be adjusted for optimum uniformity of background illumination.
5. Measured with the shrinking raster method in the centre of the screen under typical operating conditions, adjusted for optimum spot size at a beam current $I_b = 10 \mu A$ (measured on x-plates).
6. The writing speed is defined as the maximum speed at which a written trace is just visible starting from a background which is just black. The indicated value is guaranteed for the central 75% of the minimum screen area, except the outmost 4 mm of the screen. However, in any corner not more than 4 square divisions fall outside the guaranteed area. The writing speed can be increased, if some background is tolerated. Within the same area, a trace, written with the indicated value of max. write, remains just visible within the indicated storage time of max. write.
The writing speed in max. write, with background, is defined as the maximum speed at which the written trace remains just visible within the indicated storage time.
7. The storage time in just black mode is defined as the time required for the brightness of the unwritten background to rise from zero brightness to 10% of saturated brightness. At reduced intensity (by pulsing the flood beams) the storage time can be increased.
The storage time in max. write is related to the writing speed.
8. The sensitivity at a deflection less than 75% of the useful scan will not differ from the sensitivity at a deflection of 25% of the useful scan by more than the indicated value.
9. A graticule, consisting of concentric rectangles of 72 mm x 54 mm and 69,8 mm x 52,5 mm is aligned with the electrical x-axis of the tube. With optimum corrections applied, a raster will fall between these rectangles.
10. The tube has a rotation coil, concentrically wound around the tube neck, to allow alignment of the x-trace with the mechanical x-axis of the screen. The coil has 2000 turns and a maximum resistance of 650 Ω . Under typical operating conditions, a maximum of 20 ampere-turns is required for the maximum rotation of 5°. This means the required supply is 10 mA maximum at 8 V maximum.
11. The d.c. voltage on the first accelerator of the flood guns (FGA) should be equal to the mean x-plate potential.