



6840
TWIN TRIODE
 Five-Star Tube
 ★★☆☆★

FOR FREQUENCY-DIVIDER SERVICE IN COMPUTER APPLICATIONS

**HIGH PERVEANCE
 MEDIUM-MU**

**SHOCK, VIBRATION RATINGS
 HEATER-CYCLING RATING**

DESCRIPTION AND RATING

The 6840 is a miniature medium-mu twin triode primarily designed for service in computer applications. As required for this service, the tube incorporates an extremely high zero-bias plate current and a sharp-cutoff characteristic.

Intended for use in critical industrial and military applications in which operational dependability is of primary importance, the 6840 exhibits a high degree of mechanical strength and incorporates a heater-cathode construction capable of withstanding many-thousand cycles of intermittent operation. When used in on-off control applications, the tube will maintain its emission capabilities after long periods of operation under cutoff conditions.

GENERAL

ELECTRICAL

	Series	Parallel	
Cathode—Coated Unipotential			
Heater Voltage, AC or DC	12.6 ± 5%	6.3 ± 5%	Volts
Heater Current	0.4	0.8	Amperes
Direct Interelectrode Capacitances*			
Grid to Plate, Each Section		5.5	μμf
Input, Each Section		4.0	μμf
Output, Section 1		0.70	μμf
Output, Section 2		0.65	μμf
Heater to Cathode, Each Section		7.5	μμf
Grid to Grid, maximum		0.03	μμf
Plate to Plate, maximum		1.0	μμf

* Without external shield.

MECHANICAL

Mounting Position

Preferred Orientation—Upright or with Plate Majors in Vertical Position

Permissible Orientation—Any

Envelope—T-6½, Glass

Base—E9-1, Small Button 9-Pin

BASING DIAGRAM

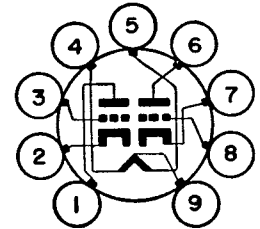

RETMA 9CZ

TERMINAL CONNECTIONS

- Pin 1—Plate (Section 2)
- Pin 2—Cathode (Section 2)
- Pin 3—Grid (Section 2)
- Pin 4—Heater
- Pin 5—Heater
- Pin 6—Plate (Section 1)
- Pin 7—Cathode (Section 1)
- Pin 8—Grid (Section 1)
- Pin 9—Heater Center Tap

PHYSICAL DIMENSIONS

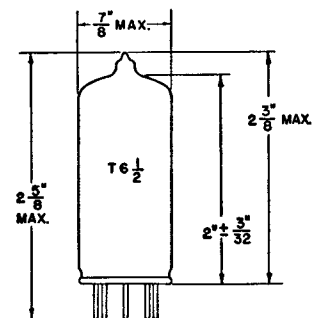

RETMA 6-3



MAXIMUM RATINGS

DESIGN-MAXIMUM VALUES, EACH SECTION†

Plate Voltage	300	Volts
Peak Positive Pulse Plate Voltage	600	Volts
Positive DC Grid Voltage	1.0	Volts
Negative DC Grid Voltage	75	Volts
Peak Positive Grid Voltage††	22	Volts
Peak Negative Grid Voltage	300	Volts
Plate Dissipation, Each Plate	4.0	Watts
Total Plate Dissipation, Both Plates	7.0	Watts
DC Grid Current	2.0	Milliamperes
Peak Grid Current††	70	Milliamperes
DC Cathode Current	35	Milliamperes
Peak Cathode Current††	500	Milliamperes
Heater-Cathode Voltage		
Heater Positive with Respect to Cathode§	100	Volts
Heater Negative with Respect to Cathode§	100	Volts
Grid Circuit Resistance		
With Fixed Bias	0.1	Megohms
With Cathode Bias	0.5	Megohms
Bulb Temperature at Hottest Point	185	C

† Design-Maximum Ratings are the limiting values expressed with respect to bogie tubes at which satisfactory tube life can be expected to occur for the types of service for which the tube is rated. Therefore, the equipment designer must establish the circuit design so that initially and throughout equipment life no design-maximum value is exceeded with a bogie tube under the worst probable operating conditions with respect to supply-voltage variation, equipment component variation, equipment control adjustment, load variation, and environmental conditions.

†† Rating based on a pulse of 10 microsecond duration, 1 percent duty cycle, and 1000-cycle repetition rate.

§ For pulse voltages of less than 1-percent duty cycle, the peak voltage may be 150 volts maximum.

CHARACTERISTICS AND TYPICAL OPERATION

AVERAGE CHARACTERISTICS, EACH SECTION

Plate Voltage	80	100	250	Volts
Grid Voltage	¶	-6.5	Volts
Cathode-Bias Resistor	620	Ohms
Amplification Factor	20	
Plate Resistance, approximate	3000	Ohms
Transconductance	6700	Micromhos
Plate Current	31	0.10	14	Milliamperes

¶ With grid current adjusted for approximately 200 microamperes.

CHARACTERISTICS LIMITS

		Minimum	Maximum	
Heater Current				
Ef = 12.6 volts	Initial	370	430	Milliamperes
	500-Hr**	370	435	Milliamperes
	1000-Hr**	370	440	Milliamperes
Zero-Bias Plate Current (1), Each Section				
Ef = 12.6 volts, Eb = 80 volts, Ic = 200 μ a (Rg = 0.40 meg to +80 volts)	Initial	26	Milliamperes
	500-Hr†	24	Milliamperes
	500-Hr**	24	Milliamperes
	1000-Hr**	22	Milliamperes
Plate Current, Each Section				
Ef = 12.6 volts, Eb = 250 volts, Rk = 620 ohms (by-passed)	Initial	11.0	17.0	Milliamperes
	500-Hr ϕ	9.8	Milliamperes
	1000-Hr ϕ	9.1	Milliamperes
Transconductance, Each Section				
Ef = 12.6 volts, Eb = 250 volts, Rk = 620 ohms (by-passed)	Initial	5300	8100	Micromhos
Zero-Bias Plate Current Change with Heater Voltage, Each Section				
Difference between Zero-Bias Plate Current (1) and Zero-Bias Plate Current at Ef = 11.4 volts (other conditions the same) expressed as a percentage of Zero-Bias Plate Current (1)				
	Initial	15	Percent
	500-Hr**	15	Percent
Amplification Factor, Each Section				
Ef = 12.6 volts, Eb = 250 volts, Rk = 620 ohms (by-passed)	Initial	16	24	
Grid Voltage Cutoff, Each Section				
Ef = 12.6 volts, Eb = 100 volts, Ib = 100 μ a	Initial	-8.5	Volts
	500-Hr†	-8.5	Volts
Interelectrode Capacitances				
Measured without external shield.				
Grid to Plate (g to p), Each Section	Initial	4.5	6.7	μ μ f
Input (g to k+h), Each Section	Initial	3.0	5.0	μ μ f
Output (p to k+h), Section 1	Initial	0.56	.84	μ μ f
Output (p to k+h), Section 2	Initial	0.51	0.77	μ μ f
Heater to Cathode (h to k), Each Section	Initial	5.5	9.1	μ μ f
Grid to Grid (g to g)	Initial	0.03	μ μ f
Plate to Plate (p to p)	Initial	1.0	μ μ f
Negative Grid Current, Each Section				
Ef = 12.6 volts, Eb = 250 volts, Rk = 620 ohms (by-passed), Rg = 0.5 meg	Initial	1.0	Microamperes
	500-Hr ϕ	1.0	Microamperes
	500-Hr**	1.0	Microamperes
	1000-Hr ϕ	1.0	Microamperes
	1000-Hr**	1.0	Microamperes
Heater-Cathode Leakage Current, Each Section				
Ef = 12.6 volts, Ehk = 100 volts				
Heater Positive with Respect to Cathode				
	Initial	7	Microamperes
	500-Hr ϕ	7	Microamperes
	500-Hr**	7	Microamperes
	1000-Hr ϕ	7	Microamperes
	1000-Hr**	7	Microamperes
Heater Negative with Respect to Cathode				
	Initial	7	Microamperes
	500-Hr ϕ	7	Microamperes
	500-Hr**	7	Microamperes
	1000-Hr ϕ	7	Microamperes
	1000-Hr**	7	Microamperes

CHARACTERISTICS LIMITS (Continued)

Interelectrode Leakage Resistance

$E_f = 12.6$ volts. Polarity of applied d-c interelectrode voltage is such that no cathode emission results.

Minimum Maximum

Grid (Each Section) to All at 100 Volts DC	Initial	100	Megohms
	500-Hr ϕ	50	Megohms
	500-Hr**	50	Megohms
Plate (Each Section) to All at 300 Volts DC	Initial	100	Megohms
	500-Hr ϕ	50	Megohms
	500-Hr**	50	Megohms

Vibrational Noise Output Voltage, RMS, Each Section

$E_f = 12.6$ volts, $E_{bb} = 250$ volts, $R_k = 620$ ohms (by-passed), $R_L = 2000$ ohms, Vibrational acceleration = 2.5 G at 25 cps.

Initial 300 Millivolts

Grid Emission Current, Each Section

$E_f = 15.0$ volts, $E_b = 250$ volts, $E_{cc} = -30$ volts, $R_g = 0.5$ meg

Initial 1.0 Microamperes

Pulse Cathode Current

$E_f = 12.6$ volts, $E_b = 200$ volts, $E_{cc} = -30$ volts. Grid is driven 21 volts positive with a pulse of 1.0 percent duty cycle and 1000-cycle repetition rate. Pulse cathode current is measured for each section with both sections operating under pulse conditions.

Initial 400 Milliamperes
 1000-Hr $\S\S$ 350 Milliamperes

ϕ Regular Intermittent Life Test: Conditions of operation for each section are $E_f = 12.6$ volts, $E_b = 250$ volts, $R_k = 620$ ohms, $R_g = 0.5$ meg, $E_{hk} = 180$ volts with heater positive with respect to cathode, and bulb temperature = 185 C minimum.

**Zero-Bias Life Test: Conditions of operation for each section are $E_f = 12.6$ volts, $E_{bb} = 125$ volts, $R_L = 1500$ ohms, and $I_c = 200 \mu a$ ($R_g = 0.62$ meg to +125 volts).

‡ Cutoff Life Test: Conditions of operation for each section are $E_f = 12.6$ volts, $E_b = 150$ volts, $E_c = -30$ volts, $R_g = 0.1$ meg, and $E_{hk} = 180$ volts with heater positive with respect to cathode.

$\S\S$ Pulse Life Test: Conditions of operation for each section are $E_f = 12.6$ volts, $E_{bb} = 180$ volts, $E_{cc} = -30$ volts, $R_L = 50$ ohms, and $R_g = 25$ ohms. Grid is driven with a 25 volt positive-going pulse (measured on driver side of R_g) of 1 percent duty cycle and 1000-cycle repetition rate.

SPECIAL TESTS AND RATINGS

Stability Life Test

Statistical sample operated for one hour to evaluate and control initial variations in zero-bias plate current.

Survival-Rate Life Test

Statistical sample operated for one hundred hours to evaluate and control early life electrical and mechanical in-operatives.

Heater-Cycling Life Test

Statistical sample operated for 2000 cycles minimum to evaluate and control heater-cathode defects. Conditions of test include $E_f = 7.5$ volts (parallel-heater connection) cycled for one minute on and one minute off, $E_b = E_c = 0$ volts, and $E_{hk} = 135$ volts with heater positive with respect to cathode.

Shock Rating—450 G

Statistical sample subjected to five impact accelerations of 450 G in each of four different positions. The accelerating forces are applied by the Navy-type, High Impact (flyweight) Shock Machine for Electronic Devices or its equivalent.

Fatigue Rating—2.5 G

Statistical sample subjected to vibrational acceleration of 2.5 G for 32 hours minimum in each of three different positions. The sinusoidal vibration is applied at a fixed frequency between 25 and 60 cycles per second.

Cathode-Interface Impedance Life Test

Statistical sample operated without cathode current to evaluate and control the development of cathode interface impedance.

Altitude Rating—60,000 Feet

Statistical sample subjected to pressure of 55 millimeters of mercury to evaluate and control arcing and corona.

Note: The conditions for some of the indicated tests have deliberately been selected to aggravate tube failures for test and evaluation purposes. In no sense should these conditions be interpreted as suitable circuit operating conditions.

AVERAGE PLATE CHARACTERISTICS
 EACH SECTION

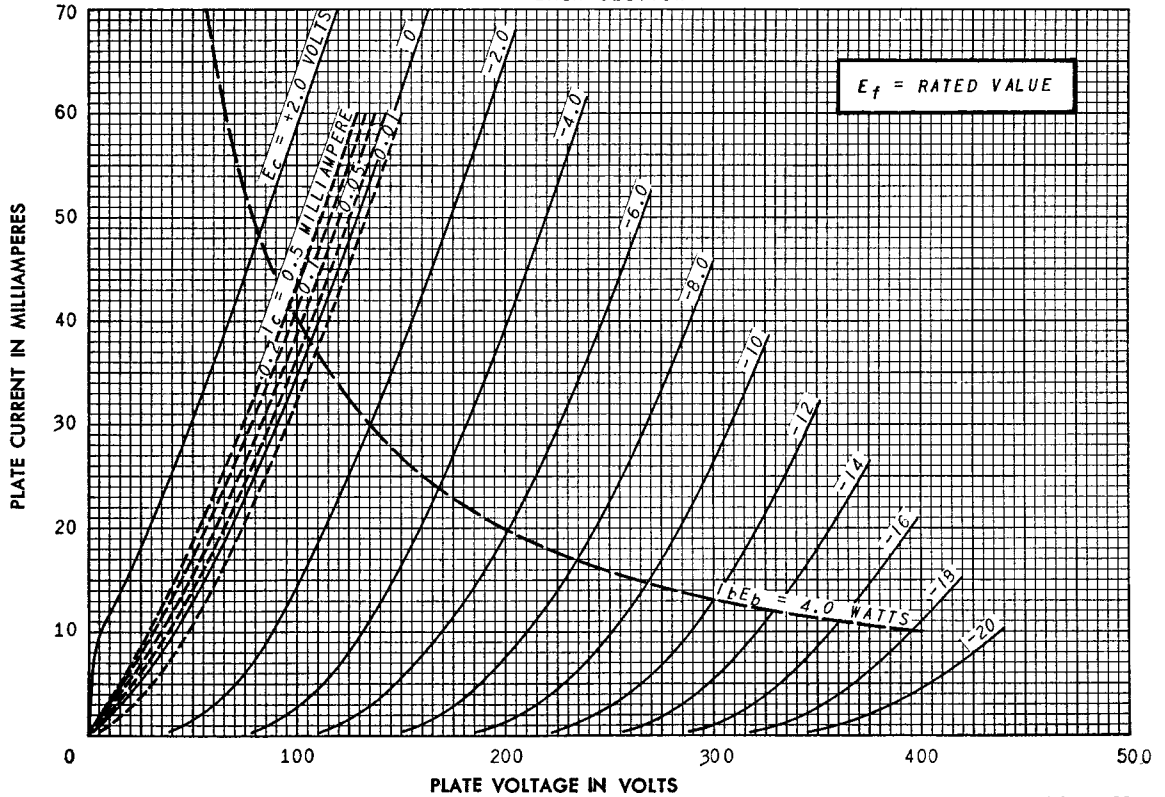

FEBRUARY 21, 1957

AVERAGE PLATE CHARACTERISTICS
 EACH SECTION

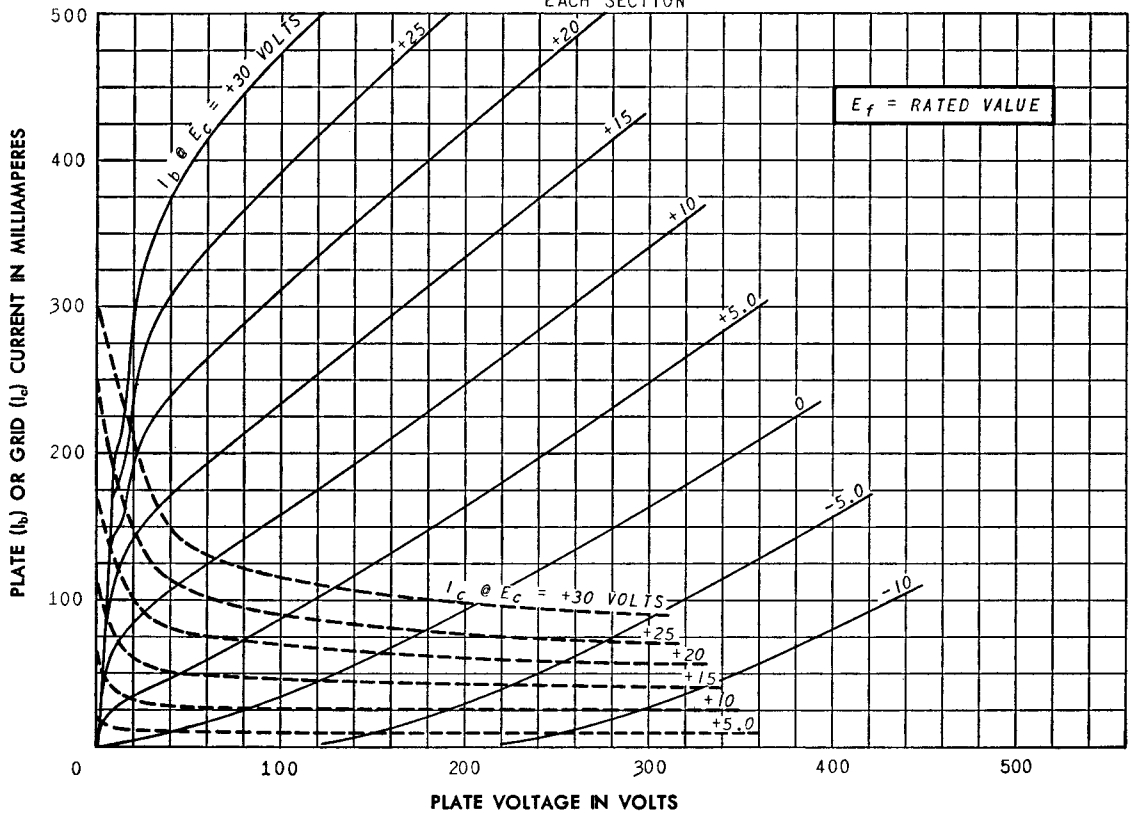

AVERAGE TRANSFER CHARACTERISTICS

EACH SECTION

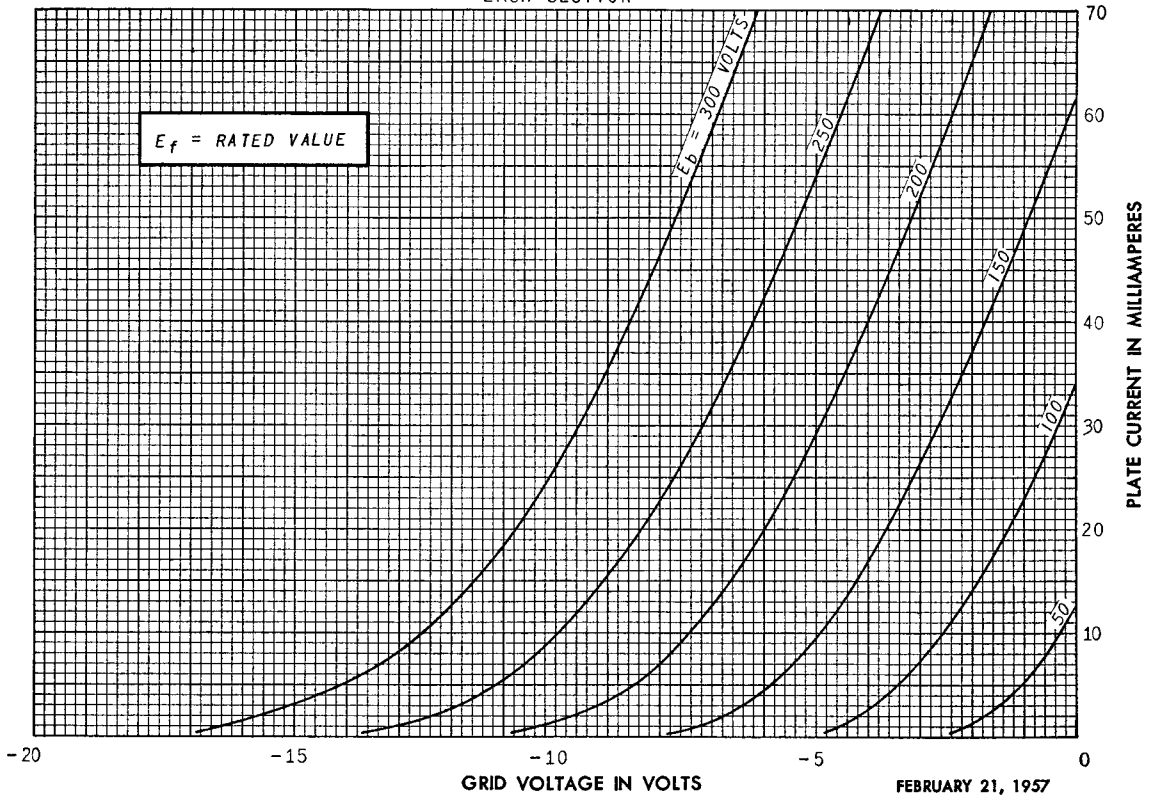

AVERAGE CHARACTERISTICS

EACH SECTION

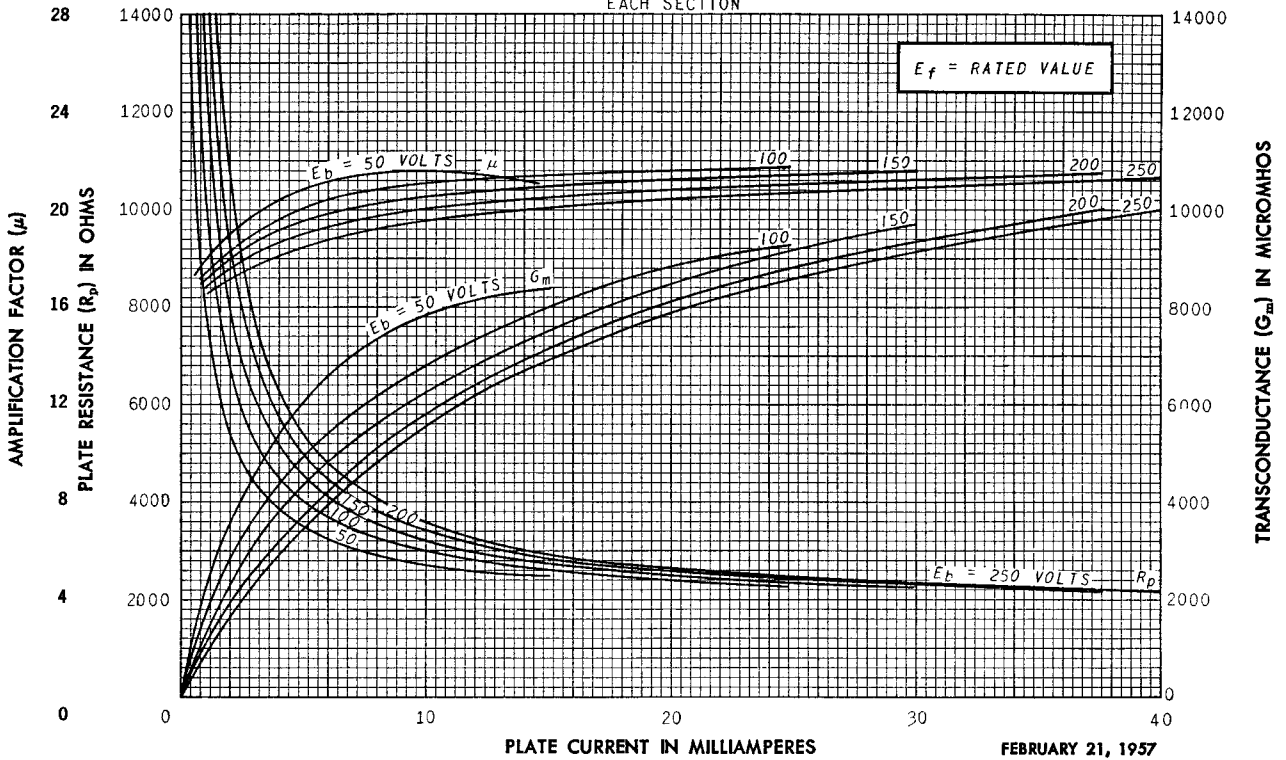

ELECTRONIC COMPONENTS DIVISION



Schenectady 5, N. Y.