

TECHNICAL INFORMATION
WESTERN ELECTRIC 1B23 VACUUM TUBE

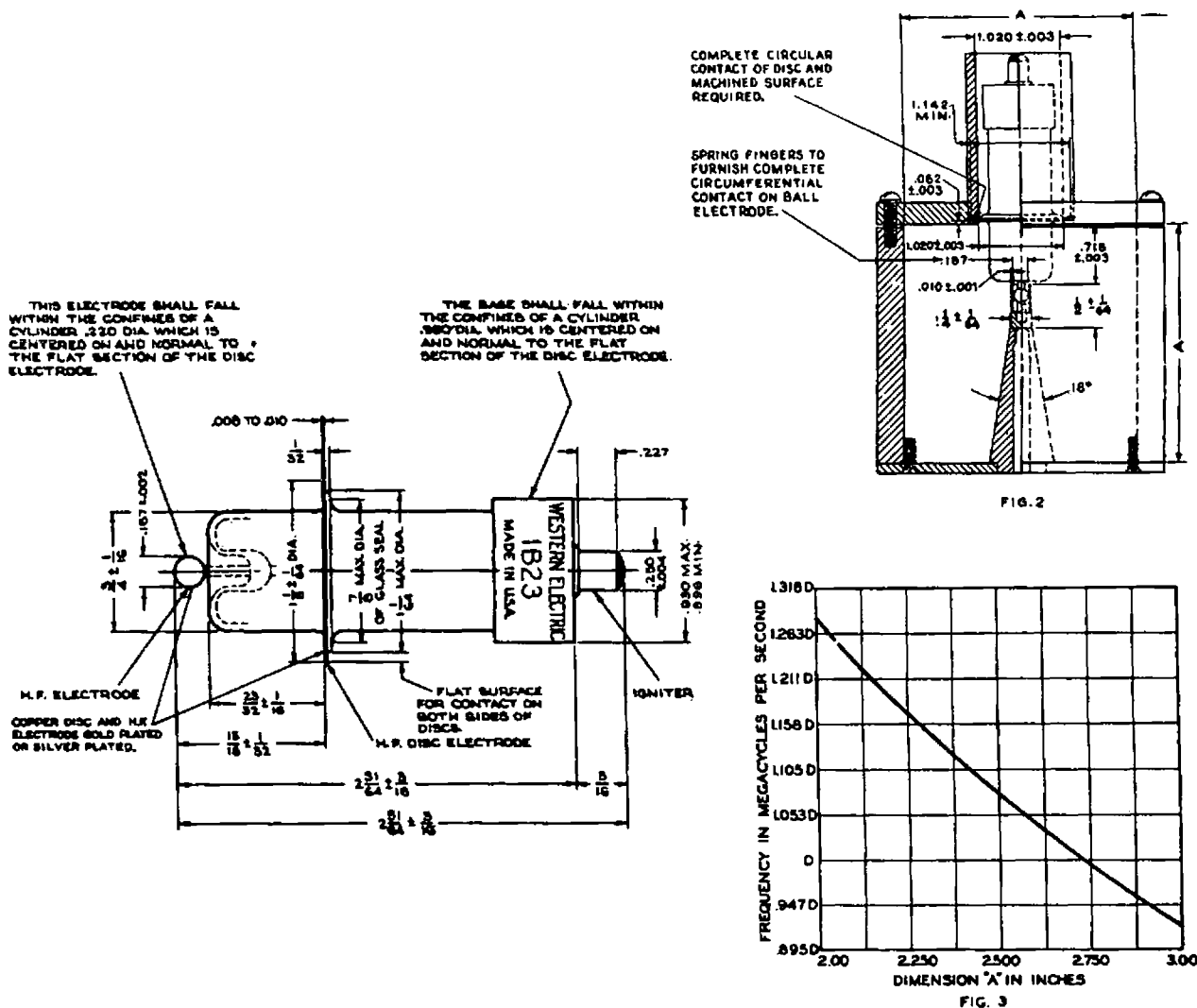

THIS ELECTRODE SHALL FALL WITHIN THE CONFINES OF A CYLINDER .320 DIA WHICH IS CENTERED ON AND NORMAL TO THE FLAT SECTION OF THE DISC ELECTRODE.

THE BASE SHALL FALL WITHIN THE CONFINES OF A CYLINDER .380 DIA WHICH IS CENTERED ON AND NORMAL TO THE FLAT SECTION OF THE DISC ELECTRODE.

M.F. ELECTRODE
COPPER DISC AND M.F. ELECTRODE GOLD PLATED OR SILVER PLATED.

FLAT SURFACE FOR CONTACT ON BOTH SIDES OF DISC
M.F. DISC ELECTRODE
IGNITER

CLASSIFICATION

The 1B23 is a double-gap, gas-filled tube for use in pulsed systems employing a common antenna, particularly those operating at frequencies below 1.263D megacycles. The ultra-high frequency gap is formed by a disc electrode and a central rod electrode which terminates in a 3/16 in. diameter ball; the auxiliary gap is provided by an igniter electrode and the disc.

MOUNTINGS AND CONNECTIONS

The tube may be mounted in any position. It should be supported only through the electrical connections to the rod and disc electrodes. These connections should be made as shown in Fig. 2. When the tube is installed in the circuit the ball electrode must be gripped along a substantially continuous circle of contact with sufficient pressure to insure a low-resistance high-frequency contact. A clamping mechanism must be provided which will insure a continuous circle of contact between the disc and the machined surface of the cavity with sufficient pressure to produce a second low-resistance high-frequency connection. This mounting must not introduce stresses on the glass seal that will either destroy or weaken the seal by complete or partial separation of the copper from the glass. Contact to the cap terminal of the igniter electrode may be made by a quick release clip.

The igniter electrode current limiting resistor should be placed at the tube terminal in order to avoid oscillations within the tube.

AMBIENT TEMPERATURE

The 1B23 tube is intended for operation over the temperature range from -40°C to +100°C. Temperatures outside this range may cause mechanical failures. As noted below, under "Operation" the electrical behavior of the tube is also temperature dependent.

TUNING

The tube is designed to operate at predetermined wave lengths to within ± 1% in fixed dimension cavities over the .947D to 1.158D megacycle frequency range. The mean value of these frequencies, as a function of cavity size, is shown in Fig. 3. These data apply to tubes mounted in cavities of the type shown in Fig. 2. The correct dimensions for cavities used in service may depart from those shown because of the effects of the input and output coupling devices and because of the need for tuning adjustments. The

NOTE: This tube is obsolete and manufacturing facilities are no longer available.

total range of the provided tuning adjustment should exceed the desired tuning range of this system by 4% of the mean frequency in order to compensate for the permitted variation between individual tubes.

OPERATION

The tube may be operated as either a receiver disconnect switch or as a transmitter disconnect switch.

When used as a receiver disconnect switch, the tube and its associated circuit effectively disconnects the receiver from the system during the transmitting period. The isolation is not complete; the amount of leakage power, i.e. the transmitter power reaching the receiver, depends upon the design and the adjustment of the circuit and to a less extent upon the power of the transmitter. Changes in the circuit adjustment to decrease the leakage power (other than those necessary to match the impedances at the input to the tube circuit) will result in an increase in the low level loss which is introduced into the received signal path. The approximate relationship between the leakage power and the ultimate low level loss for matched input conditions is given by the expression:

$$P_r = \frac{V^2}{R} \frac{T}{1-T}, \text{ watts, where } V \text{ is the radio-frequency voltage drop across the tube gap, } R \text{ is the unloaded}$$

resonant impedance of the tube and cavity measured at the gap and T is the fraction of the received signal power which is passed through the gas tube circuit. The parameter V is nearly constant over a relatively large range in the gas tube power. For purposes of computation it may be assumed to be 100 volts. The low-level loss expressed in decibels ($10 \log_{10} \frac{1}{T}$) is normally adjusted to approximately 1.0 db.

Additional leakage power reaches the receiver as a result of direct coupling between the transmitter and the receiver. Some direct coupling occurs within the cavity itself through higher order transmission modes which do not excite the tube. The amount of this directly-coupled leakage power depends upon the size and shape of the cavity and the type and relative positioning of the input and output devices. It varies directly with the power of the transmitter and is normally of importance only in high power systems. The directly-coupled attenuation is usually of the order of 60 db unless special precautions are taken to increase it.

The recovery of the tube after the transmitting period is not instantaneous. The additional loss after the transmitting period varies with the ambient temperature from a few db at 20°C or higher to approximately 50 db at -40°C. At normal temperatures this loss decreases rapidly with time, returning to within 3 db of the ultimate low level loss value in approximately 2 microseconds.

The power dissipated in the tube during the transmitting period varies with the transmitter power, with the effectiveness of the tube circuit, and with the circuit adjustment. The approximate relationship

is given by the expression: $P_g = \left[\frac{V^2 P}{R(1-T)} \right]^{1/2}$ watts, where P is the transmitter output and $V, R,$ and T

have the same meanings as before.

When used as a transmitter disconnect switch, the tube and its associated circuit effectively disconnect the transmitter from the circuit during the receiving period. Some low level loss is introduced so that of the received power only a definite fraction F of this will be directed toward the receiver. The power dissipated in the tube during the transmitting period varies with the circuit adjustment, being given

by the expression: $P_g = \left[\frac{P V^2 F}{R(1-F)} \right]^{1/2}$, watts, where the symbols have their previous meanings.

CIRCUIT REQUIREMENTS

Since the unloaded resonant impedance R is a function of both the tube and cavity design, satisfactory operation can be obtained only with properly designed cavities. A measure of the quality of cavities of the same design can be made by measuring Q_0 the unloaded cavity Q . In general, cavities yielding Q_0 values less than 1500 will be unsatisfactory. If the Q_0 values for a cavity designed to have a maximum value of R has an unacceptably narrow band-width the cavity design should depart from the optimum in that direction which gives the highest value of R at the acceptable Q_0 value.

LIFE

The life expectancy of the tube will vary greatly with the power requirements which the system places on the tube, and on the value of the DC igniter current. The greater the current, the less the useful life.

STARTING DISCHARGE

When the tube is used to protect receivers which may be damaged by a temporary overload, a continuous low current discharge must be maintained between the igniter and the adjacent copper disc. The igniter should be negative. A d-c source of 800 volts or more with a current limiting resistance of sufficient value to limit the discharge current to approximately 100µA is satisfactory. When the starting discharge is not required, no connection need be provided to the igniter.

RATING

For the tube mounted in the cavity shown in Fig. 2 with dimension A of 2.750 inches.

Operating frequency (D) ± 1%	As specified for the type
Minimum unloaded Q (Q_0)	1500
Maximum instantaneous dissipation	100 watts
Maximum average dissipation	1 watt
Approximate value of V , under conditions where the peak gas tube power is less than 100 watts (The parameter V increases gradually with temperature over the recommended operating range. Excessive values may be obtained at temperatures both above and below this range)	100 volts
Maximum igniter electrode strike voltage	800 volts dc
Maximum igniter electrode sustain voltage	500 volts dc
Minimum igniter electrode sustain voltage	300 volts dc
Maximum igniter electrode current (To be limited by series resistance)	0.1 milliamperes