

National Video Corporation

4300 W. 47TH STREET CHICAGO 32, ILLINOIS
CLIFFSIDE 4-5600

The 12BGP4 is a 12"-110° cathode ray tube with filled rim and the anode contact J1-21 located on the long side of the bulb. This tube has a 4 3/8" neck length. A straight gun which requires no ion trap. A 450 milliamperes 6.3 volt filament and 50 volt G2 for cathode drive design.

ELECTRICAL DATA

Focusing Method	Electrostatic
Deflection Method	Magnetic
Deflection Angles (Approximate)	
Diagonal	110 degrees
Horizontal	99 degrees
Vertical	80 degrees
Direct Interelectrode Capacitances	
Cathode to all other electrodes (approx.)	5 uuf
Grid No. 1 to all other electrodes (approx.)	6 uuf
External conductive coating to anode (Note 1)	850 max. uuf
	550 min. uuf
Resistance Between External Conductive Coating and Impllosion Protection Hardware	50 min. megohms
Heater Current at 6.3 Volts	450 ± 20 ma
Heater Warm-up Time	11 seconds

OPTICAL DATA

Phosphor Number	P4 Aluminized
Light Transmittance at Center (Approximate)	52 per cent
Antireflection Treatment	None

MECHANICAL DATA

Overall Length	9 5/16 +1/4 inches
Neck Length	4 3/8 +1/8 inches
Greatest Dimensions of Tube (Metal Rim)	
Diagonal	13 47/64 +1/16 inches
Width	11 13/32 +1/16 inches
Height	9 3/64 +1/16 inches
Minimum Useful Screen Dimensions (Projected)	
Diagonal	11 5/8 inches
Horizontal Axis	10 1/8 inches
Vertical Axis	7 5/8 inches
Area	74 sq. inches

Implosion Protection		Filled Rim
Bulb	JEDEC Designation	J-99-A1
Bulb Contact	JEDEC Designation	J1-21
Base	JEDEC Designation	B7-208
Basing	JEDEC Designation	8HR
Bulb Contact Alignment	J1-21 contact aligns with Pin Position No. 2 \pm 30°.	

RATINGS (Design Maximum System)

Unless otherwise specified, voltage values are positive and measured with respect to Grid #1.

Maximum Anode Voltage	15,000 volts
Minimum Anode Voltage	8,000 volts
Maximum Grid No. 4 (Focusing Electrode) Voltage	+1,100 -500 volts
Maximum Grid No. 2 Voltage	60 volts
Minimum Grid No. 2 Voltage	25 volts
Cathode Voltage	
Maximum negative value	0 volts dc
Maximum negative peak value	2 volts
Maximum positive value	100 volts dc
Maximum positive peak value	150 volts
Maximum Heater Voltage	6.9 volts
Minimum Heater Voltage	5.8 volts
Maximum Heater-Cathode Voltage	
Heater negative with respect to cathode	
During warm-up period not to exceed 15 seconds	400 volts
After equipment warm-up period	200 volts
Heater positive with respect to cathode	200 volts

TYPICAL OPERATING CONDITIONSCATHODE DRIVE SERVICE

Unless otherwise specified, all voltage values are positive with respect to Grid No. 1

Anode Voltage	12,000 volts dc
Grid No. 4 Voltage (Focusing Electrode)	250 volts dc
(Notes 3 and 4)	
Grid No. 2 Voltage	50 volts dc
Cathode Voltage (Note 2)	35 to 55 volts dc

MAXIMUM CIRCUIT VALUES

Maximum Grid No. 1 Circuit Resistance	1.5 megohms
---------------------------------------	-------------

GRAPHS AND DRAWINGS

Tube Outline with Essential Dimensions and Tolerances

ULTOR RECESSED SMALL
CAVITY CAP JEDEC J1-21
(NOTE-1)

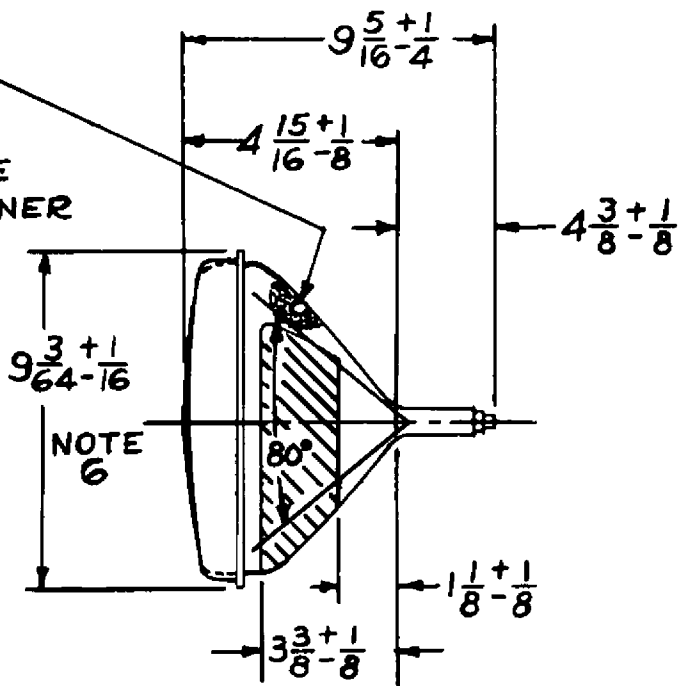
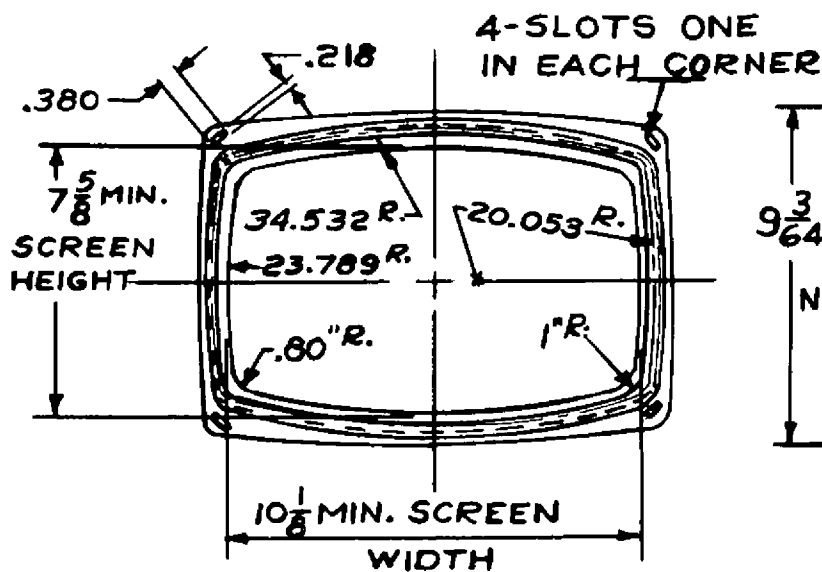

EXTERNAL CONDUCTIVE COATING (NOTE-4)

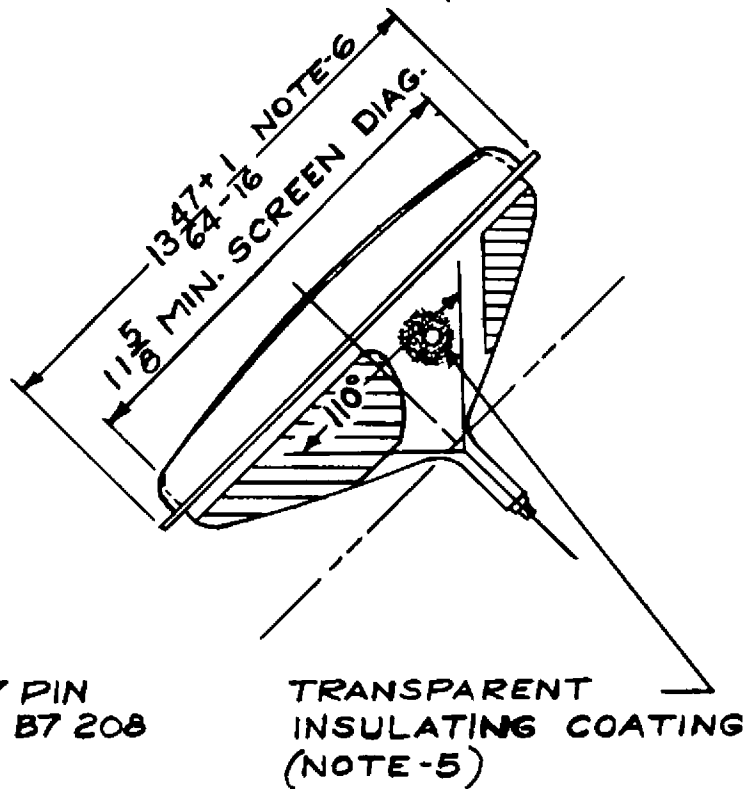
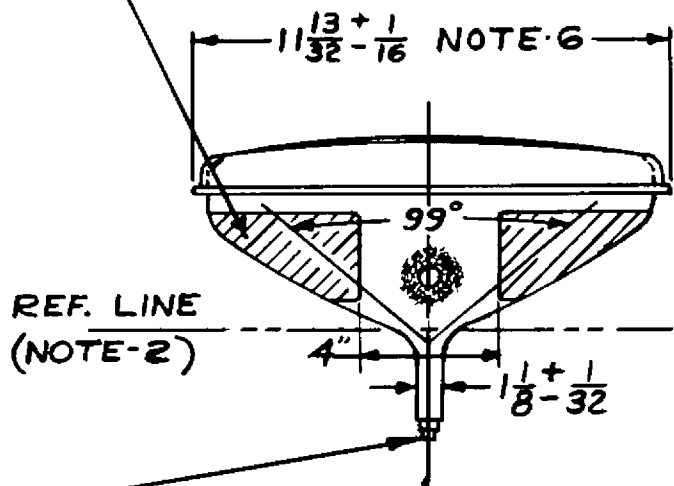

SMALL BUTTON NINEIGHTAR 7 PIN
BASE ARRANGEMENT 1 JEDEC B7 208
(NOTE 3)

CL-G3-G5
ULTOR

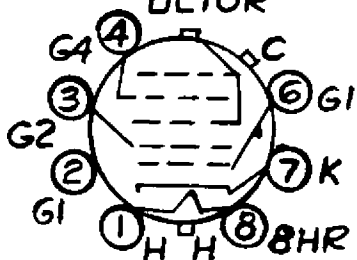

- PIN 1: HEATER
- PIN 2: GRID NO. 1
- PIN 3: GRID NO. 2
- PIN 4: GRID NO. 4
- PIN 6: GRID NO. 1
- PIN 7: CATHODE
- PIN 8: HEATER

CAP: ULTOR CL-G3-G5
C: EXTERNAL CONDUCTIVE COATING

DRAWN BY	SCALE	EFFECTIVE	DISTRIBUTION	DRG. NO.
R. ZIEMBA	~	8-28-64		12 BGP4

GRAPHS AND DRAWINGS (CONT.)

Pin Connections:

Pin 1	Heater	Pin 6	Grid #1
Pin 2	Grid #1	Pin 7	Cathode
Pin 3	Grid #2	Pin 8	Heater
Pin 4	Grid #4		

NOTES

1. Measured with implosion protection hardware connected to external coating.
2. Visual extinction of focused raster.
3. With the combined Grid No. 1 bias Voltage and video-signal voltage adjusted to give an anode current of 100 microamperes on a 10 1/8" by 7 5/8" pattern from RCA 2F21 monoscope or equivalent.
4. Individual tubes will have satisfactory focus at some value between 0 and +400 volts.

NOTES FOR DIMENSIONAL OUTLINE

1. The plane through the tube axis and Pin No. 4 may vary from the plane through the tube axis and ultor terminal by angular tolerance (measured about the tube axis) of $\pm 30^\circ$. Ultor terminal is on same side as Pin No. 2.
2. With tube neck inserted through flared end of reference-line gauge JEDEC No. G-126 and with tube seated in gauge, the reference-line is determined by the intersection of the Plane CC' of the gauge with the glass funnel.
3. Socket for this base should not be rigidly mounted; it should have flexible leads and be allowed to move freely. The design of the socket should be such that the circuit wiring cannot impress lateral strains through the socket contacts on the base pins. Bottom circumference of base wafer will fall within a circle concentric with bulb axis and having a diameter of 1 3/4".
4. External conductive coating must be grounded.
5. To clean this area, wipe only with soft dry lint-less cloth.
6. Measured at O.D. of shell.